

UPS (Uninterruptible Power Supplies)

UPS Applications



Progress Energy

Outline

- Introduction
- UPS Basics
- UPS Applications & Specifications
- Generator Sizing to Serve a UPS
- UPS Maintenance Bypass
- Conclusions

Introduction

- What is a UPS
- Uninterruptible Power Supplies (UPSs)
 - ▶ A system designed to automatically provide power, without delay or transients, during any period when the normal power supply is incapable of performing acceptably. IEEE Definition
 - ▶ Provide reliable power to critical loads
 - ▶ Improve reliability and power quality

UPS Basics

- Three fundamental topologies utilized for static UPSs
 - ▶ Standby power systems (off-line)
 - ▶ Line interactive (single conversion)
 - ▶ Double conversion (on-line)

UPS Basics

- Standby power systems (SPSs)
 - ▶ No power conditioning during normal operation
 - ▶ Load sees brief interruption when switching to battery backup
 - ▶ Square wave or stepped sine wave output under backup power
 - ▶ Typically small (up to 10 kVA), single-phase

Sine Wave vs Square Wave

Sine Wave

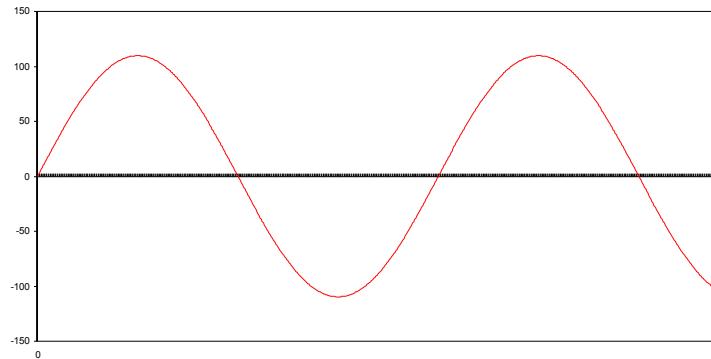

Square Wave

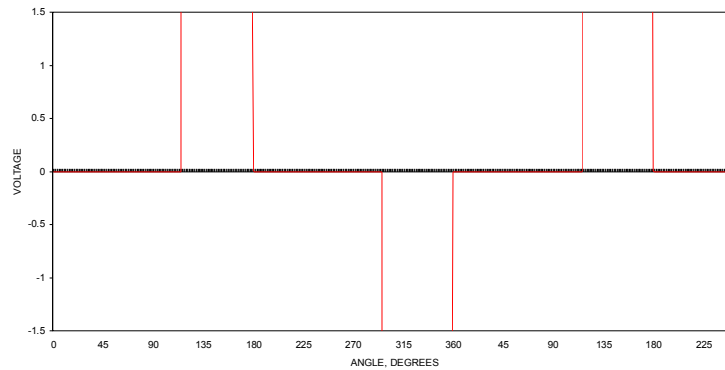

Standby Power Systems

(Off Line System)

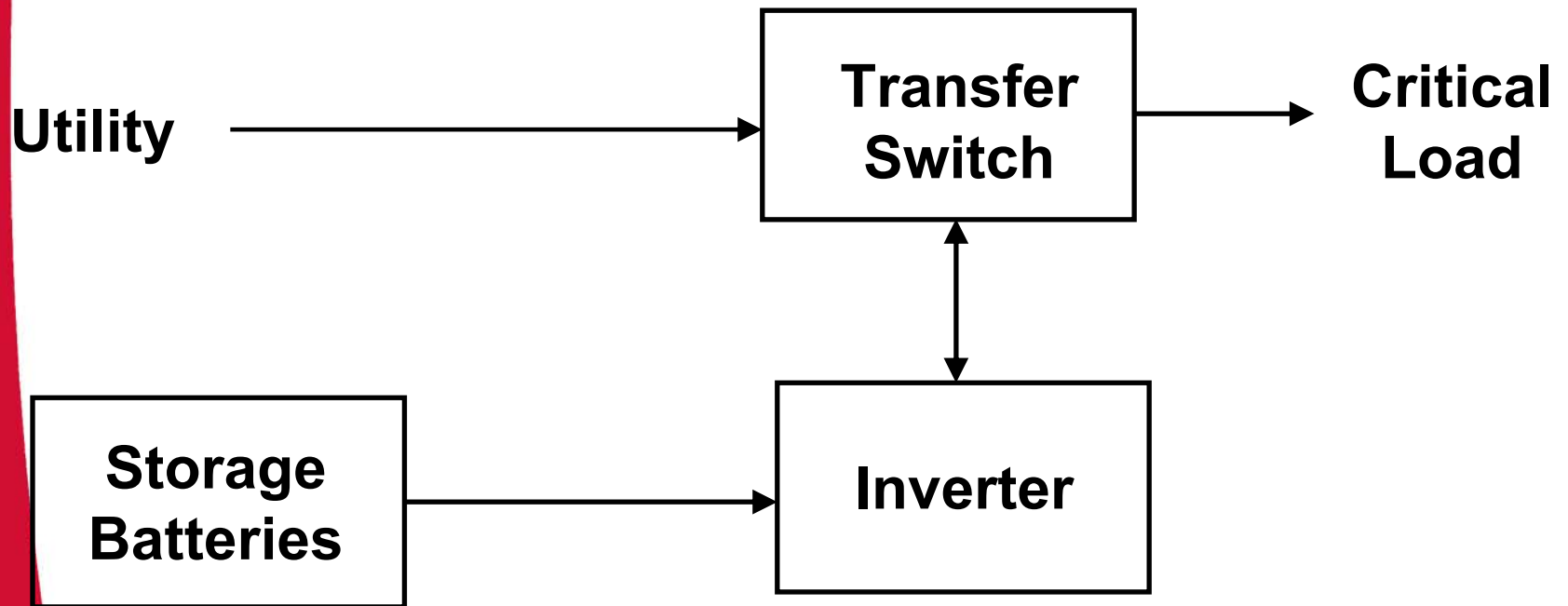

UPS Basics

- Line interactive UPSs
 - ▶ Power passed to the load through magnetic components (inductors, transformers)
 - ▶ Inverter interacts with magnetic components to boost or buck input voltage
 - ▶ Provides some power conditioning but frequency variations are passed to load
 - ▶ Typically 100 kVA or less, 1- or 3-phase

Line Interactive (Single Conversion)

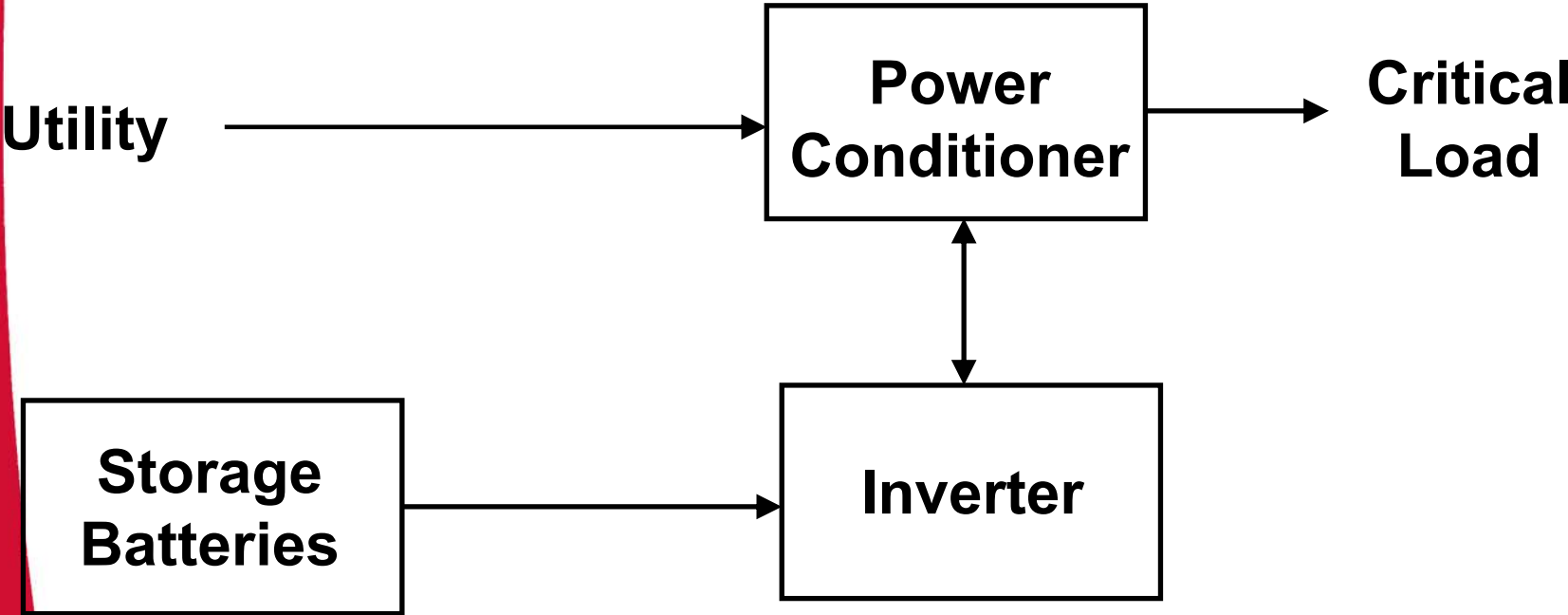

UPS Basics

- Double conversion (on-line) UPSs
 - ▶ Input voltage not passed directly to load
 - ▶ Rectifies AC to DC (where Storage are connected) then inverts back to AC
 - ▶ Seamlessly draws power from DC storage when input voltage lost
 - ▶ Independent, conditioned output power
 - ▶ Single-phase or three-phase, ratings can exceed 1000 kVA, higher if paralleled

Double Conversion (on-line)

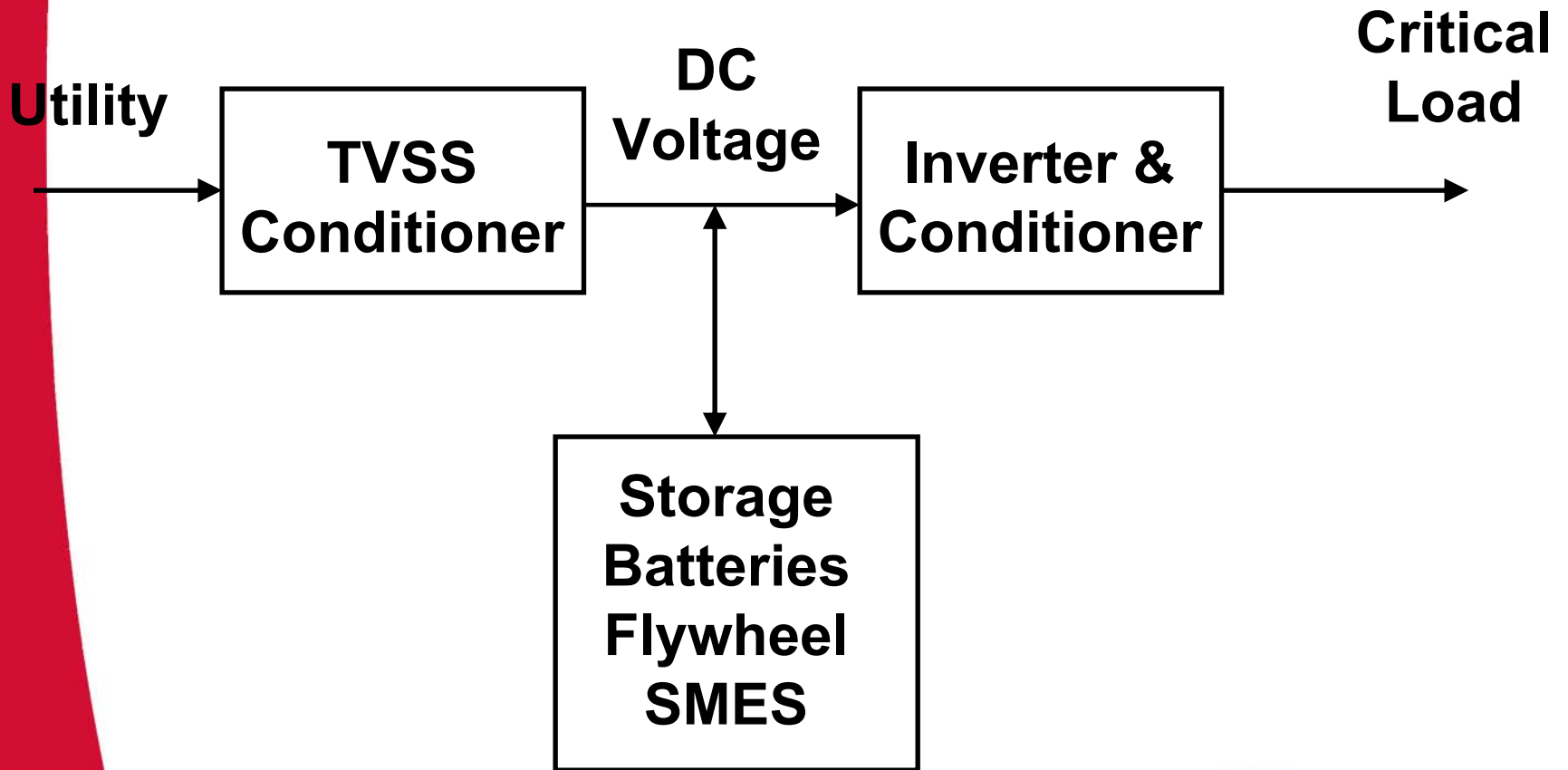

UPS Application

- ▶ Type Load
 - ◆ Computers
 - ◆ Controls
 - ▼ PLCs
 - ▼ Relays
 - ◆ Motors
- ▶ Time of Back-Up
- ▶ Generator

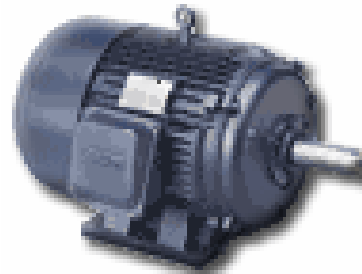
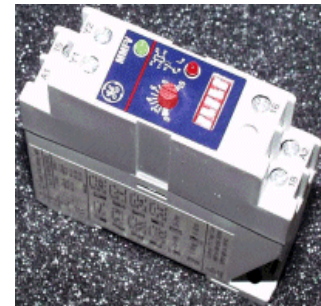

UPS Specification

- Voltage
- Load kW & kVA
- Transfer Time
- Transfer Voltage
- Waveform Output
- Type Storage & Time
- Storage Life
 - Batteries 4 to 6 years



Generators Serving UPSs

- Generators serving UPSs will need to be sized for
 - Harmonics
 - Motor starting
 - ◆ Voltage drop
 - ◆ Slew rate



UPS Maintenance Bypass

- If a load is important enough to require a UPS it is also important enough to require a proper maintenance bypass path
 - External & Internal bypass switches on larger UPSs
 - Internal bypass switches (present on most UPSs) are used for smaller UPSs

Conclusions

- UPS Basic Types
- Applications
- Specifications
- Generator Serving a UPS
- UPS Maintenance Bypass